



50Hz -Wide Screen Colour Television

FW Models



Switch Mode Power Supply

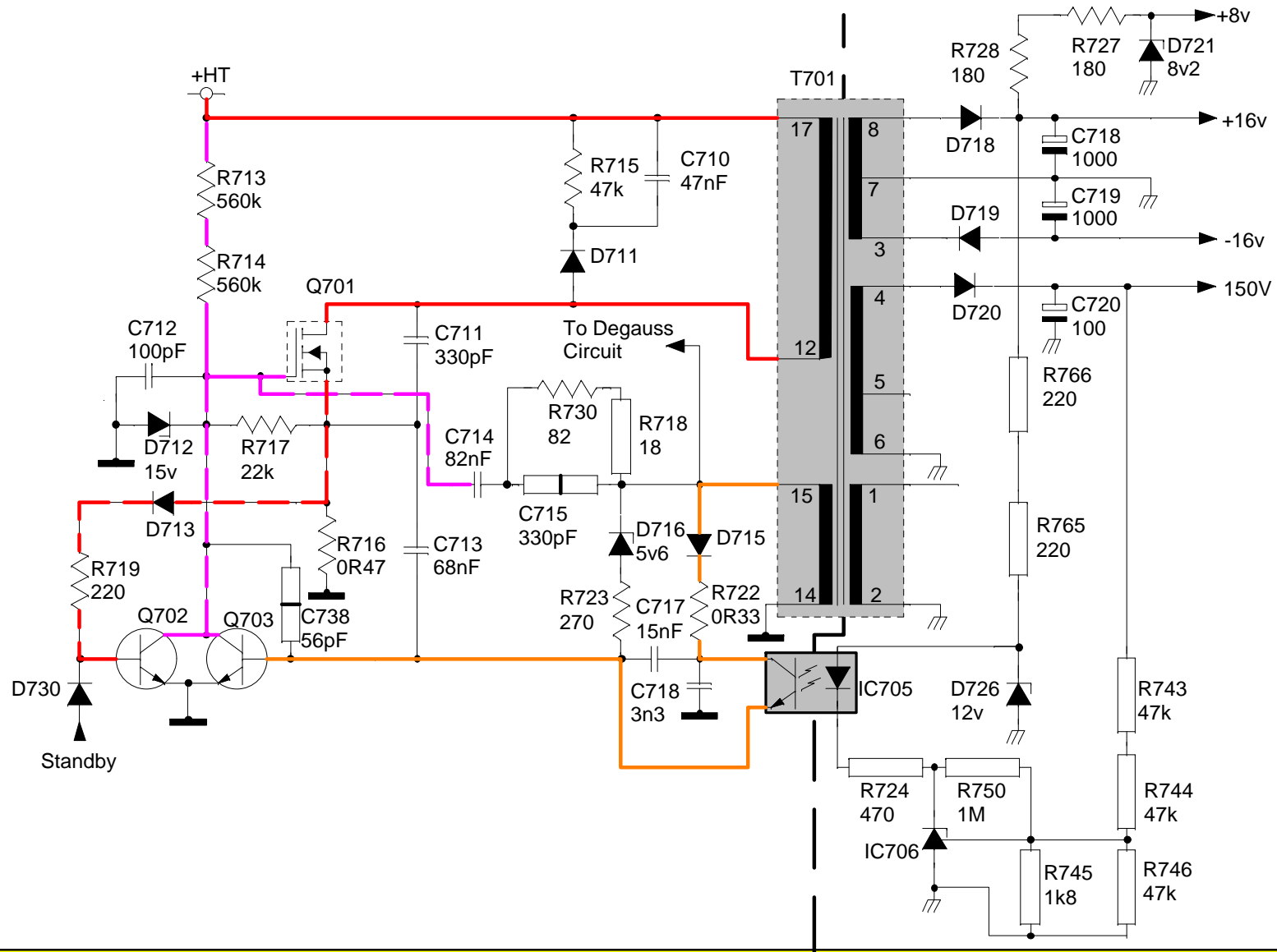

Degauss Circuit

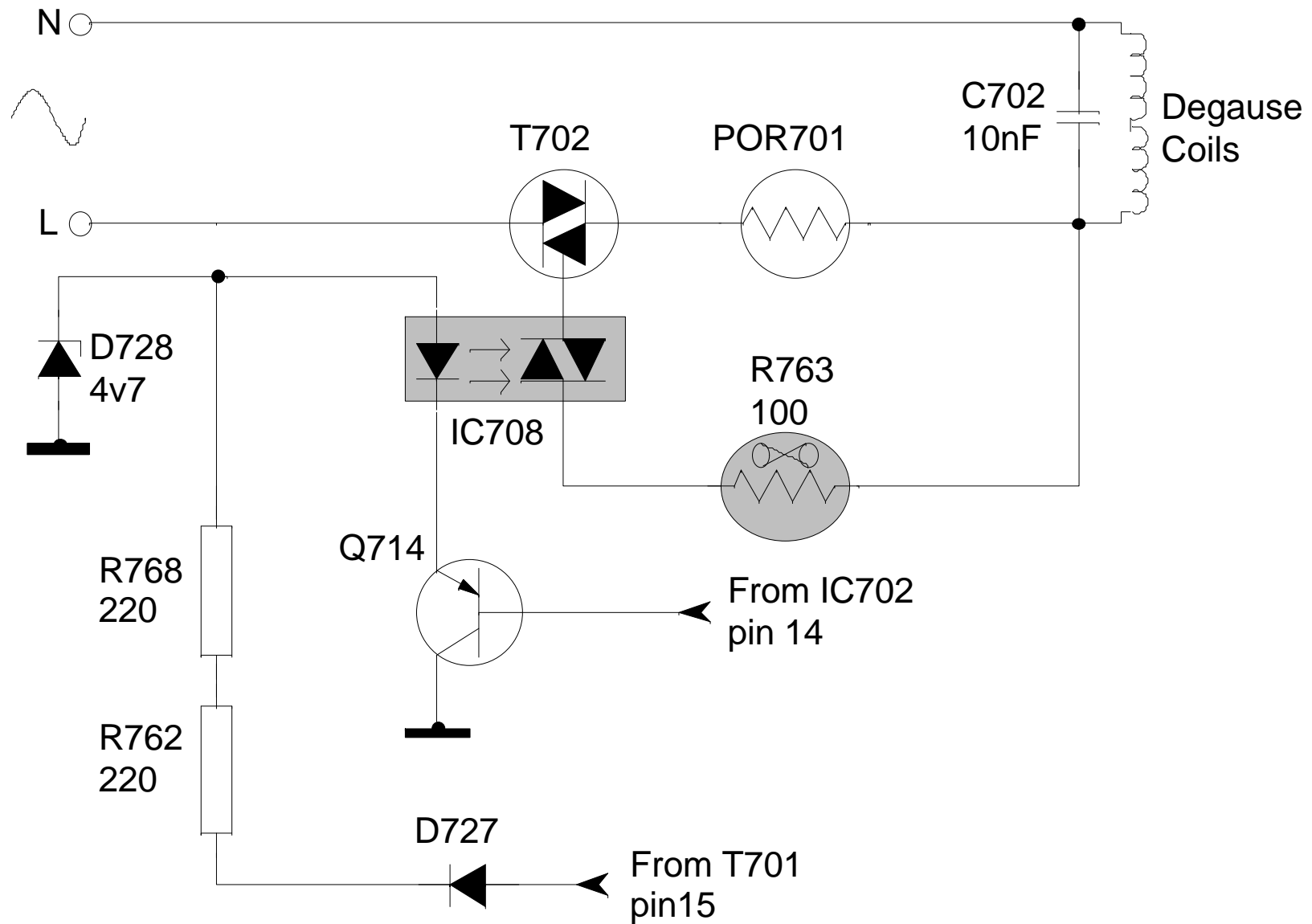

Slave 5v Supply

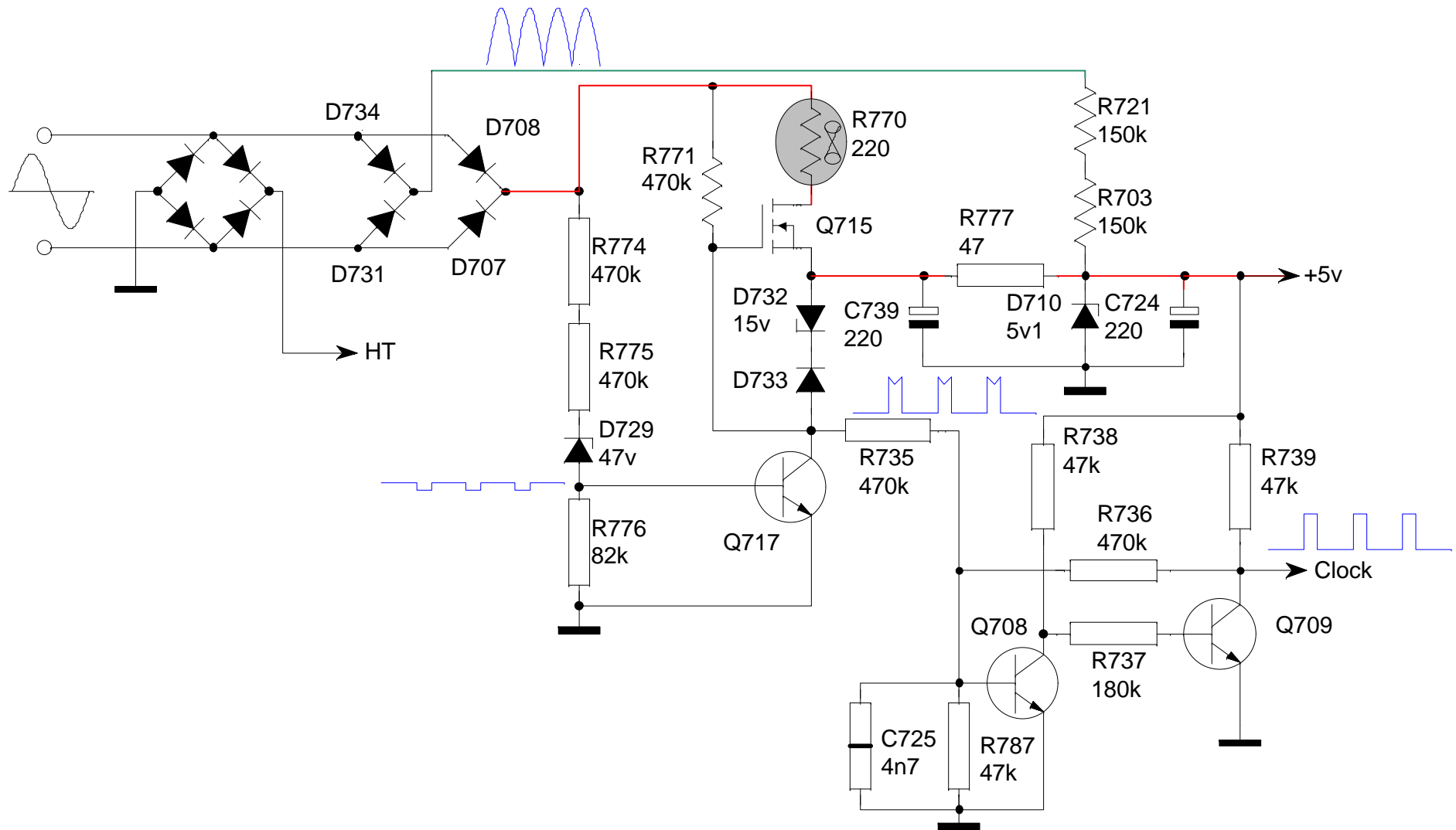

Slave Reset

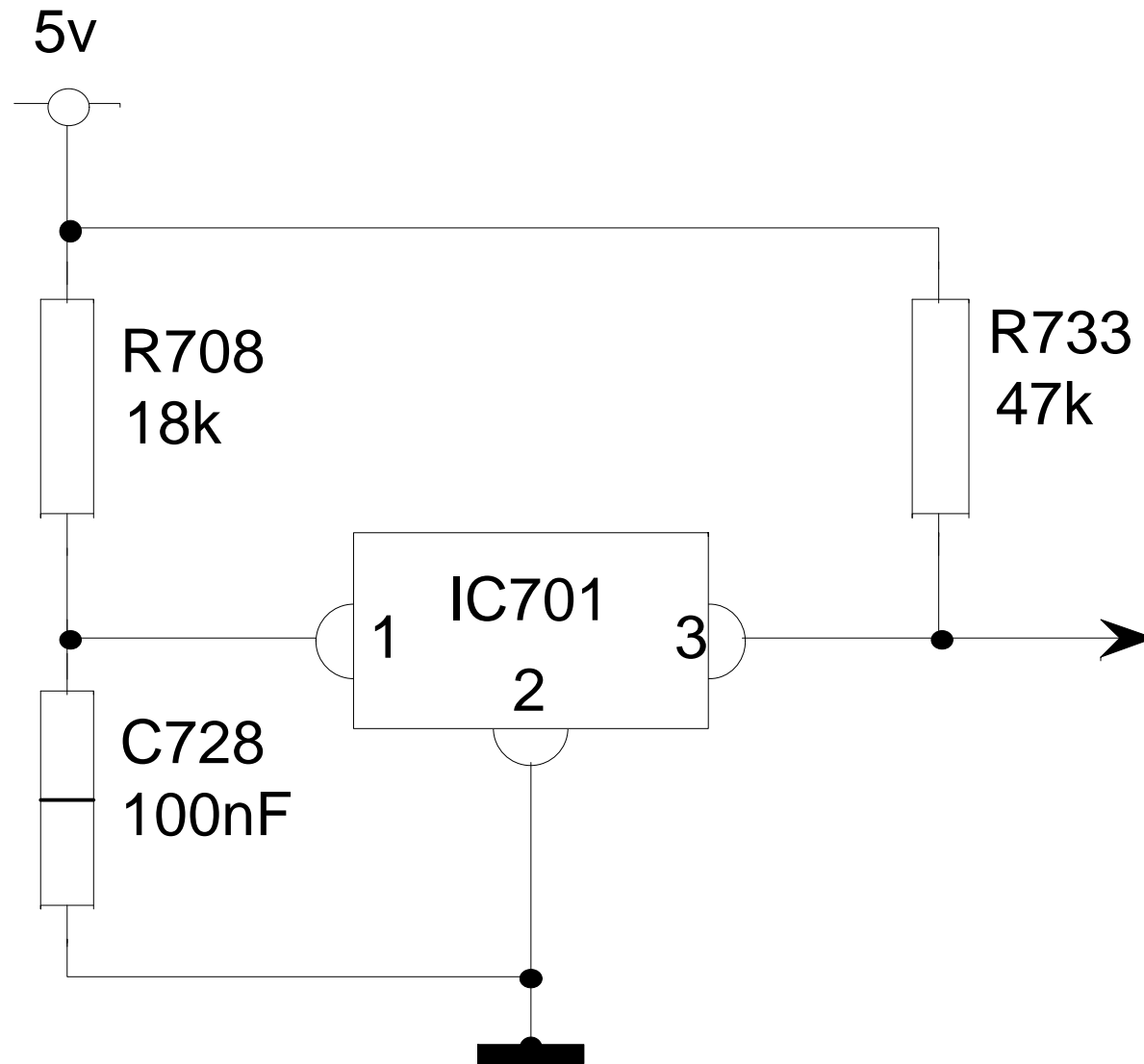

5v Regulator (DW100)

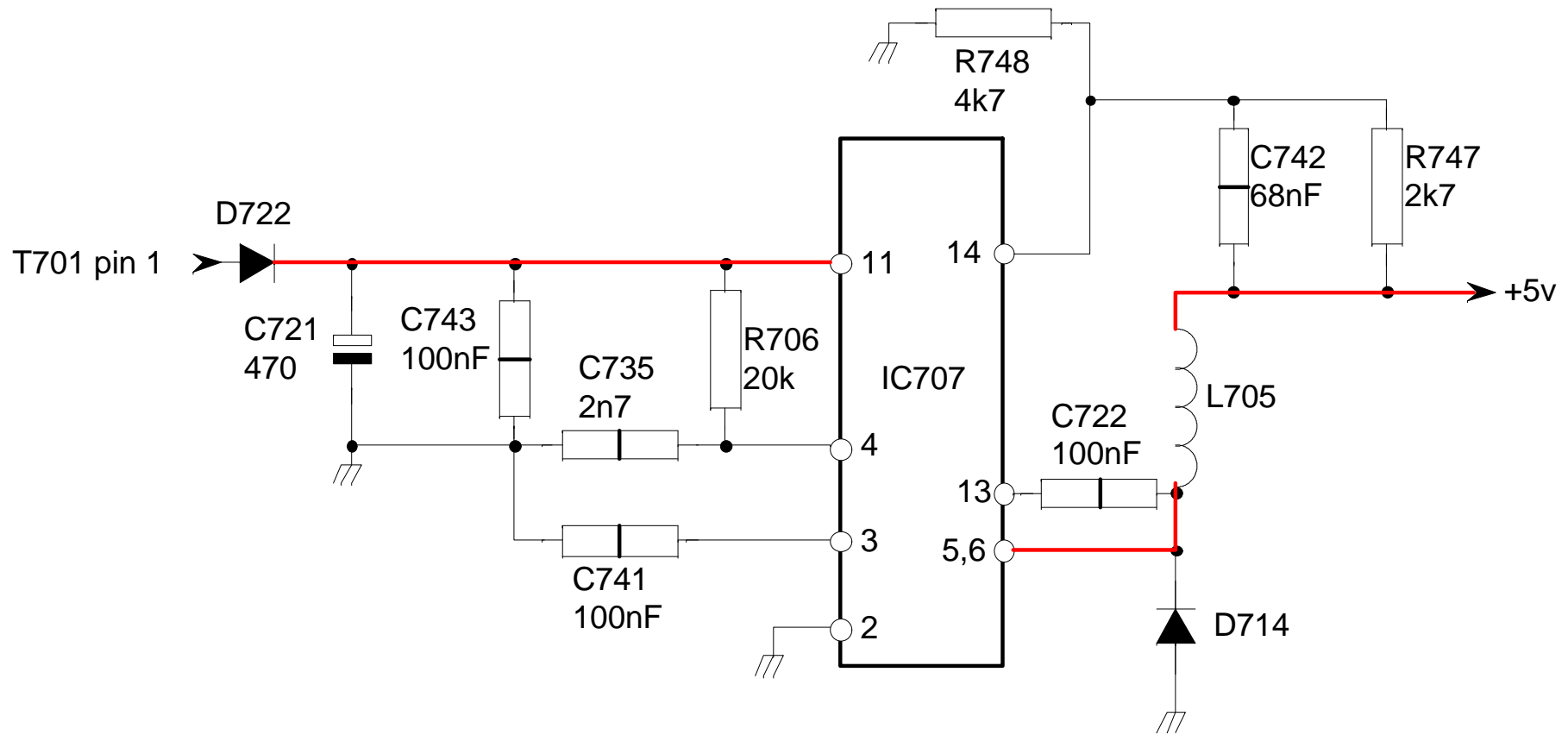

3v3 Regulator

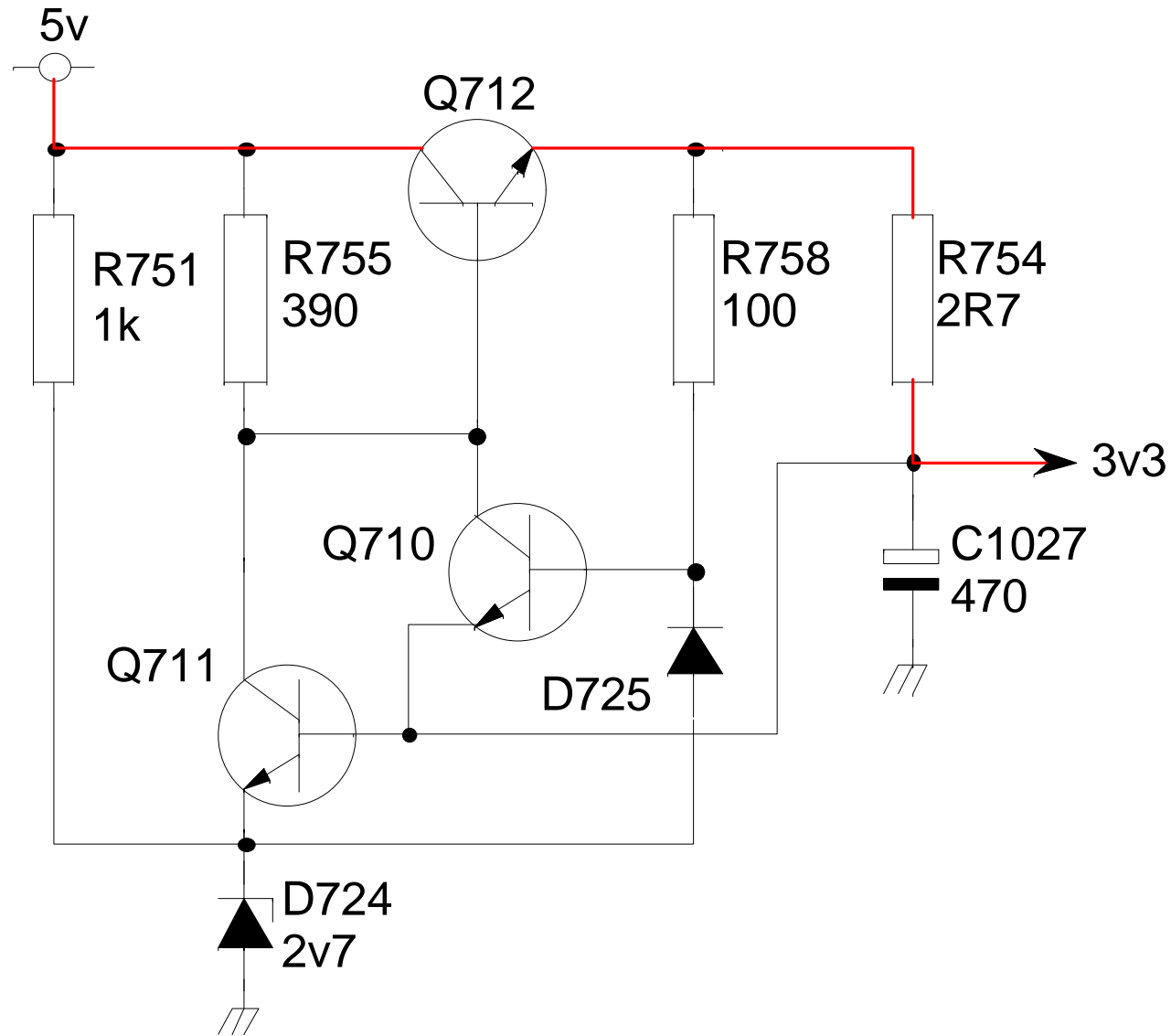

Communication Paths

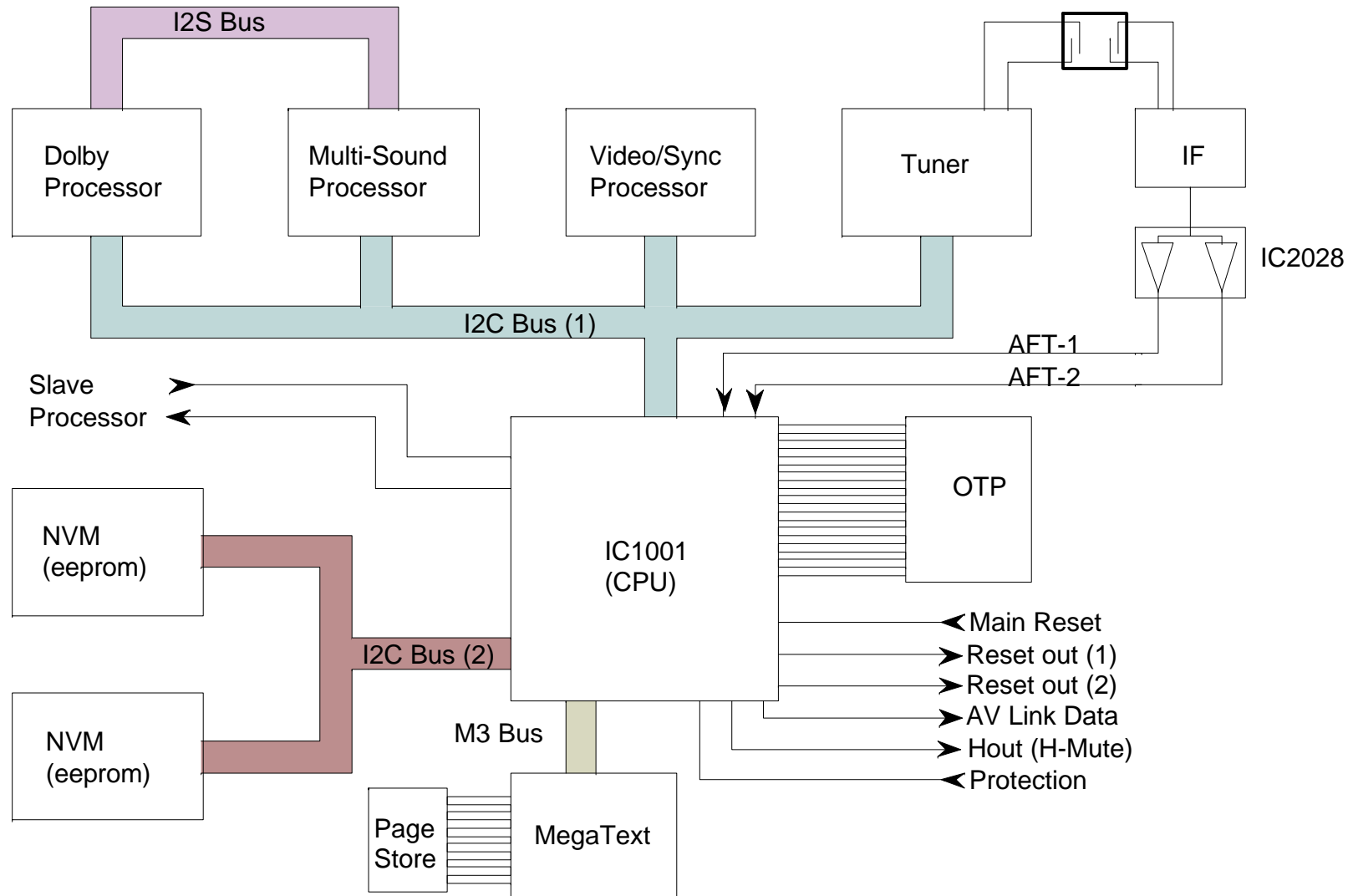

Reset-In/Line and Audio Mute

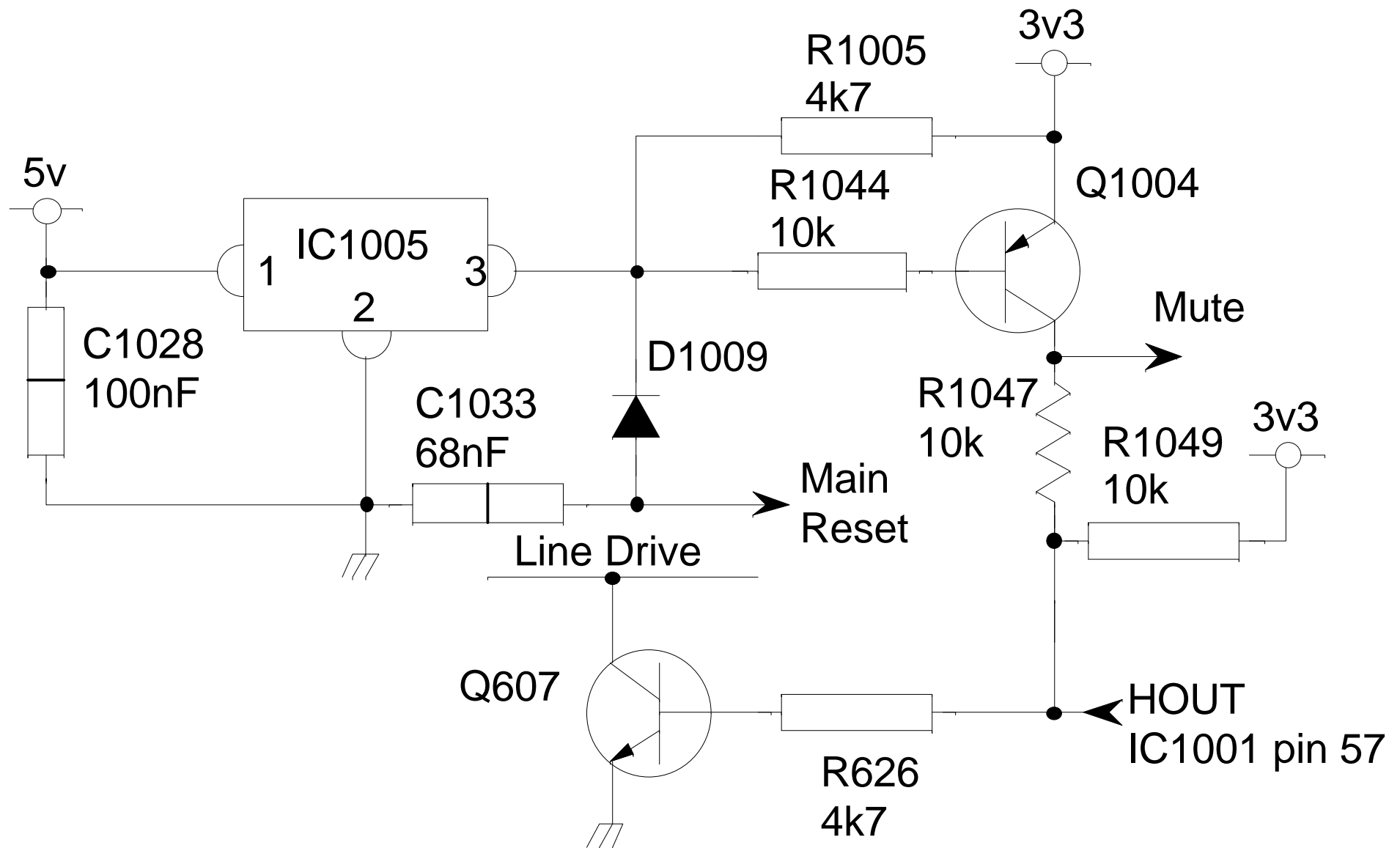

Reset-out (1)

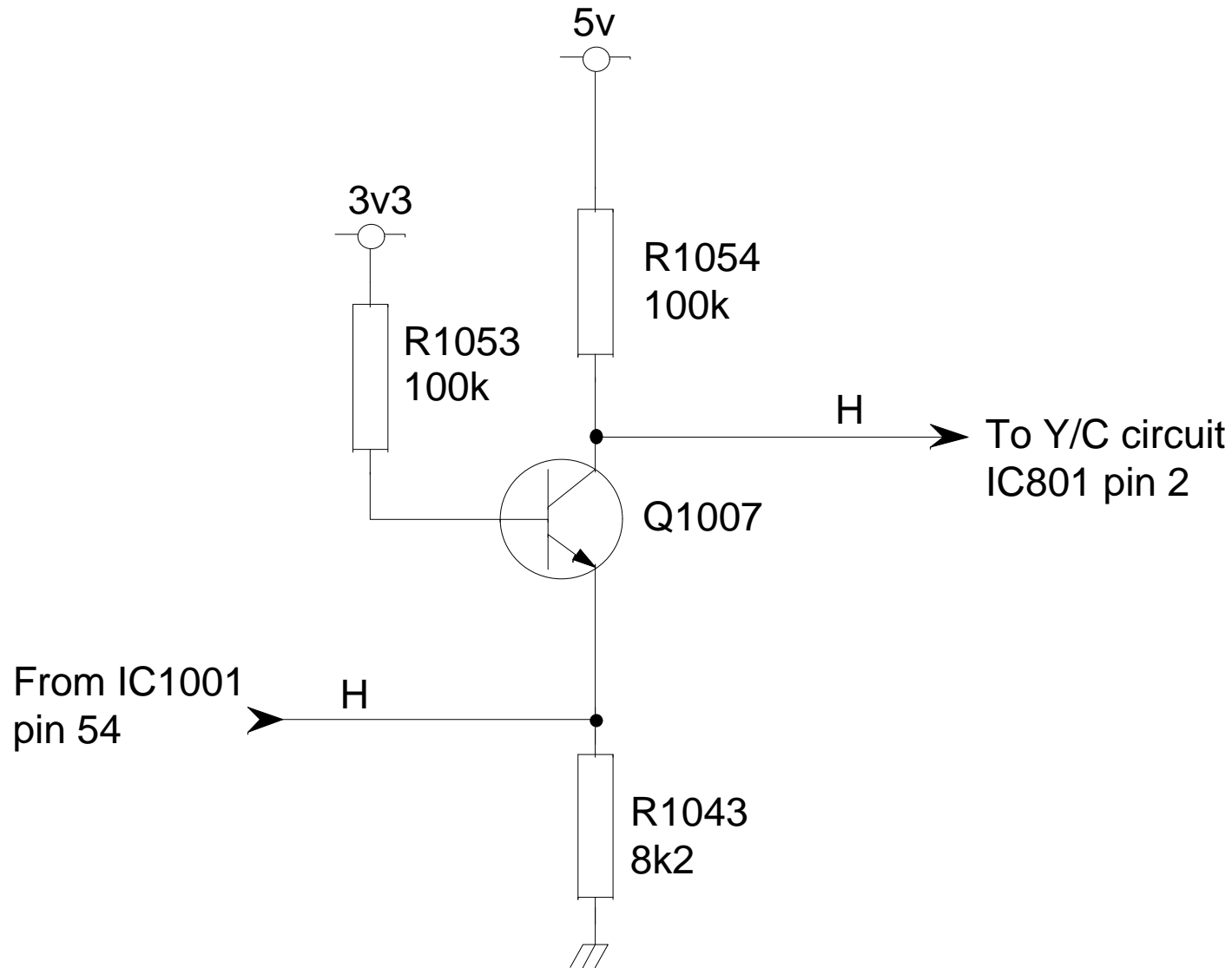

Reset-out (2)

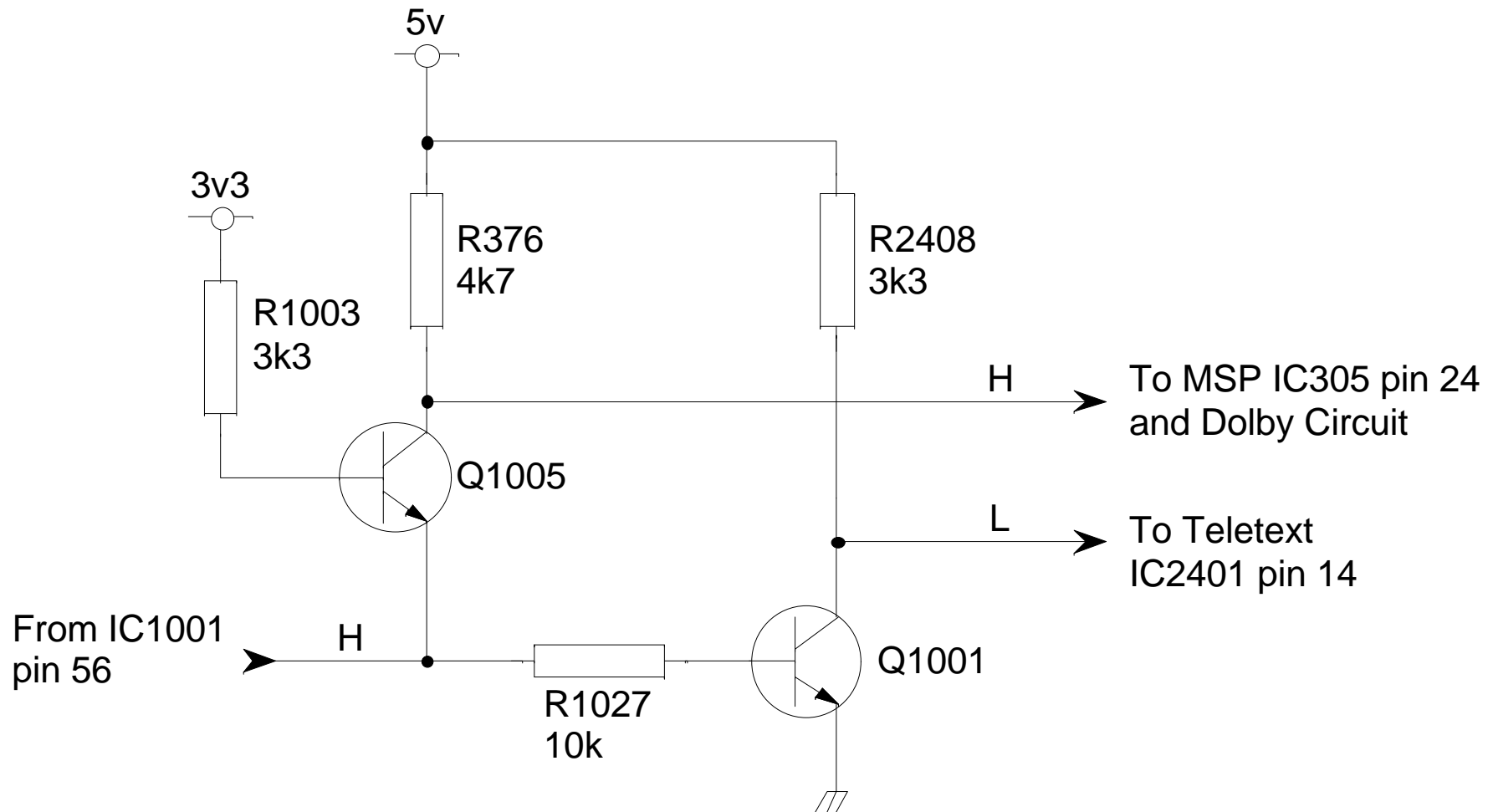

Protection

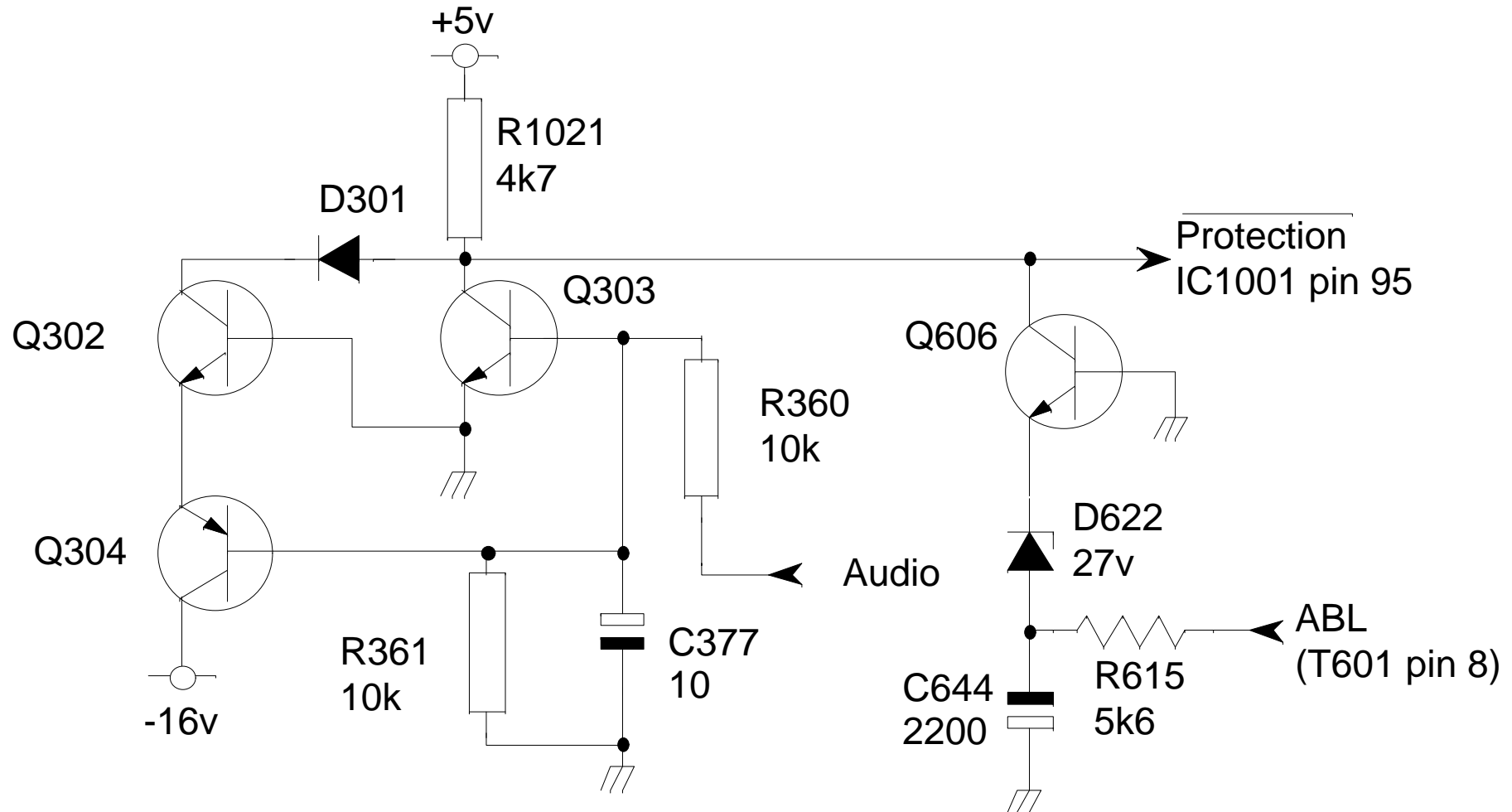

Rotation Control

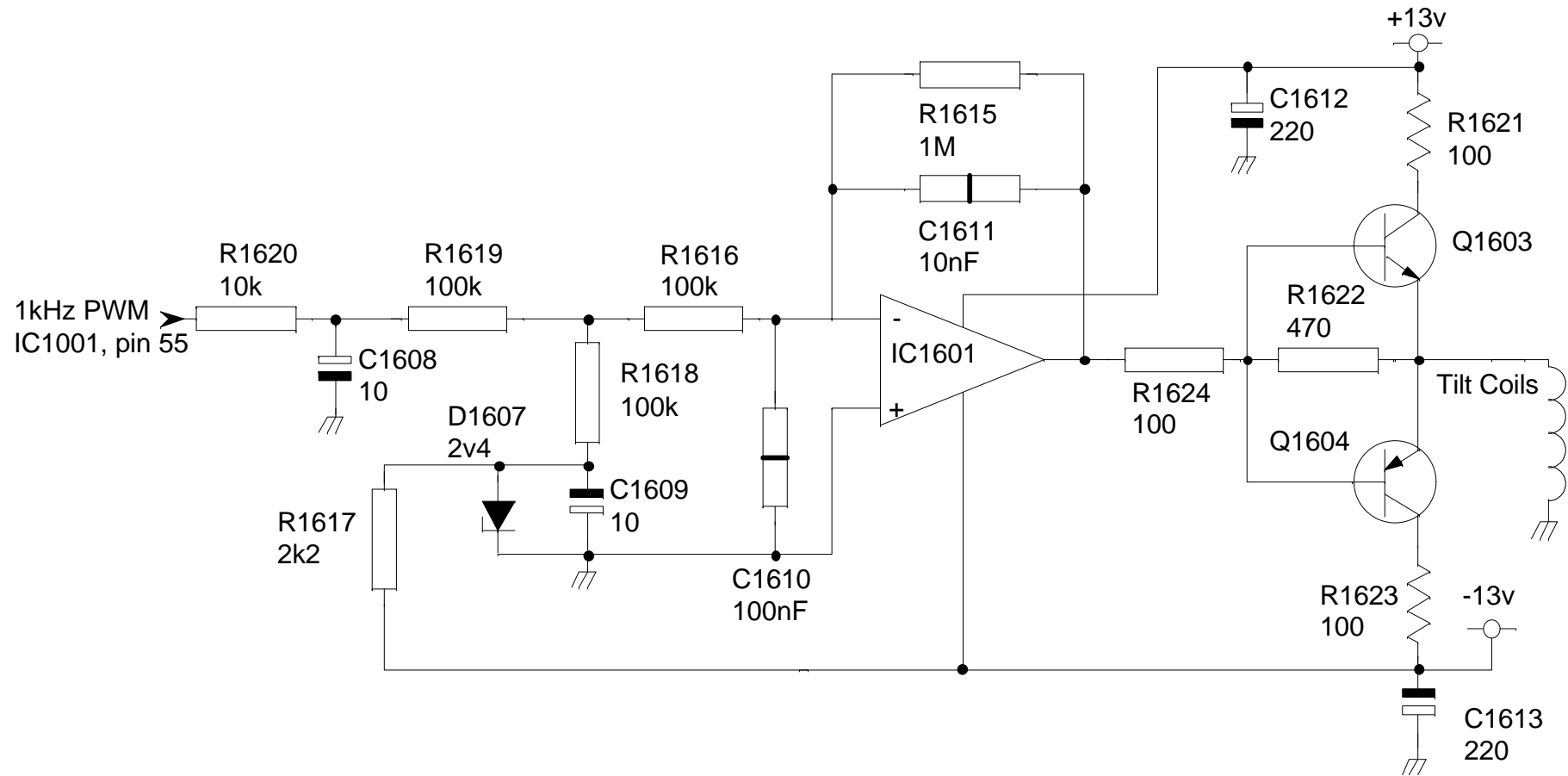

AV Link

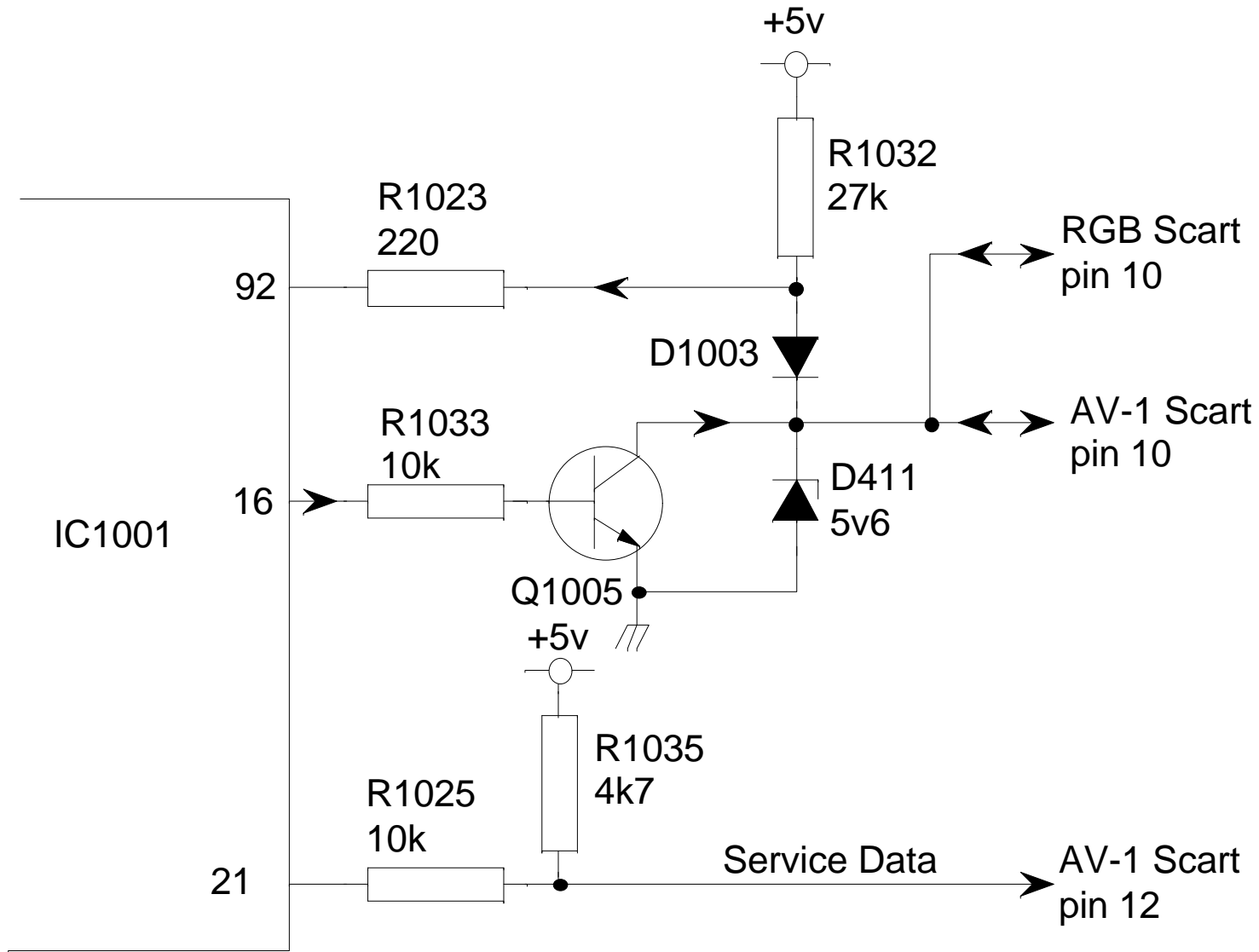

Field Output (Class D)

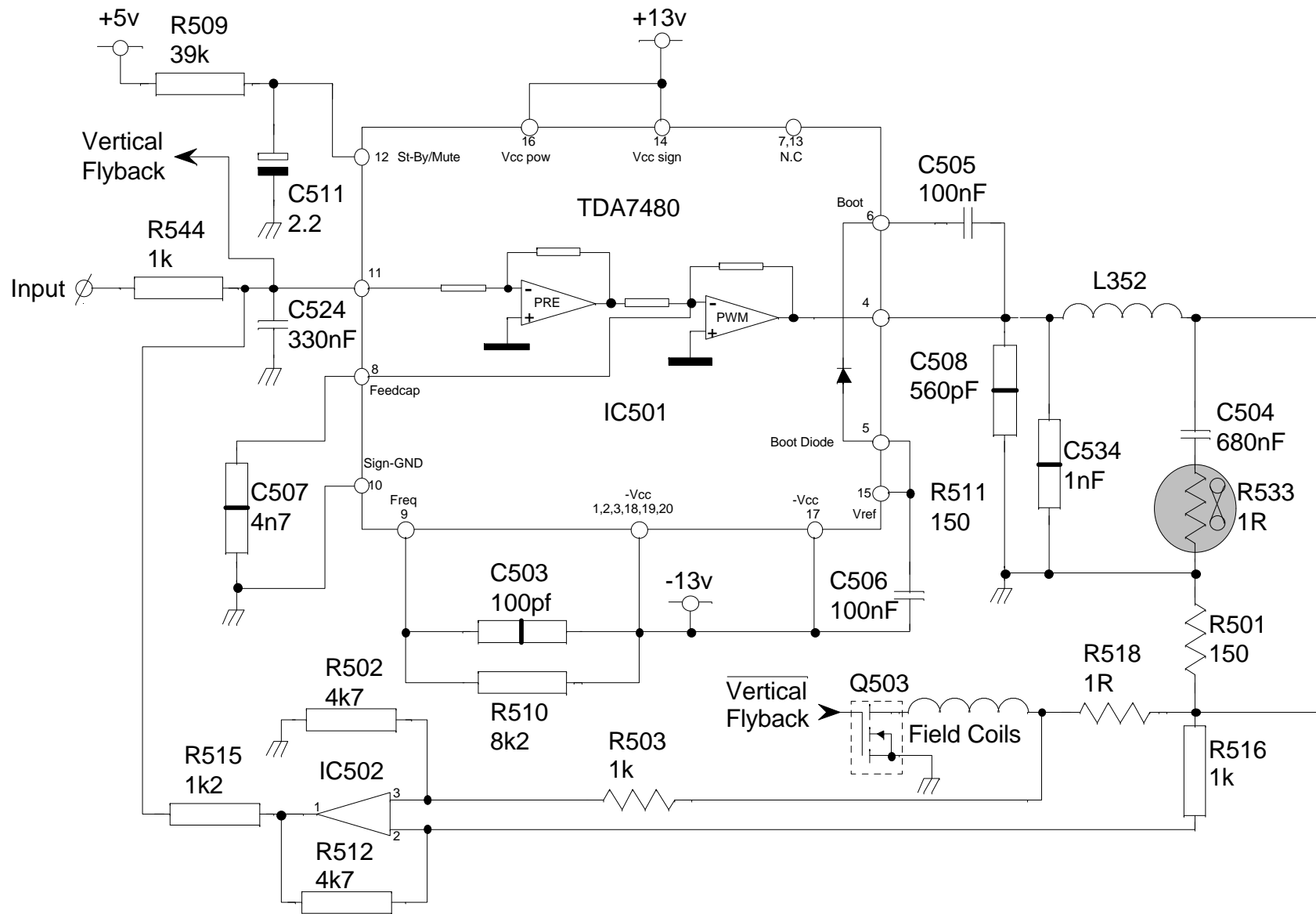

Vertical Fly-back Generator

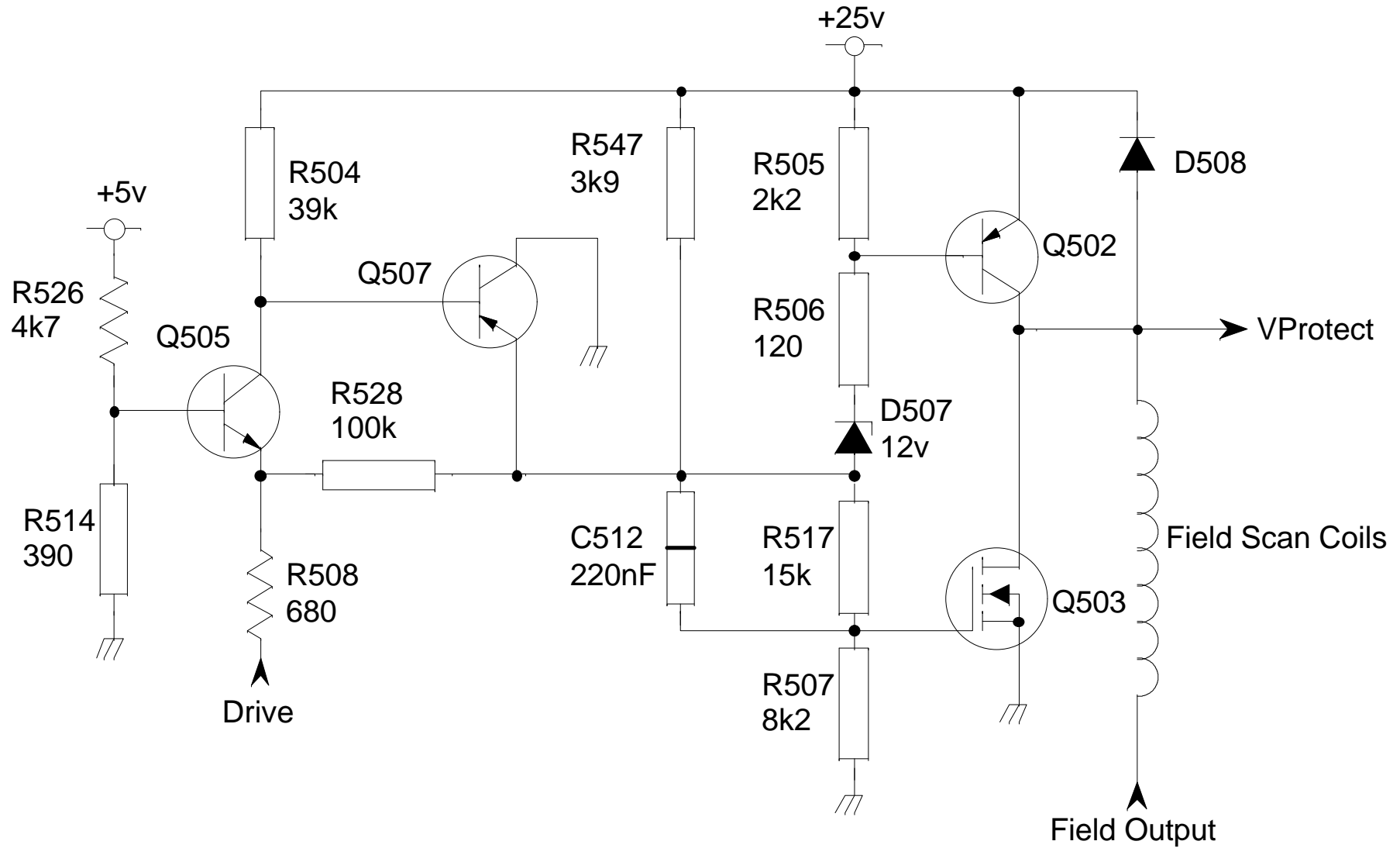

Audio Output (Class D)

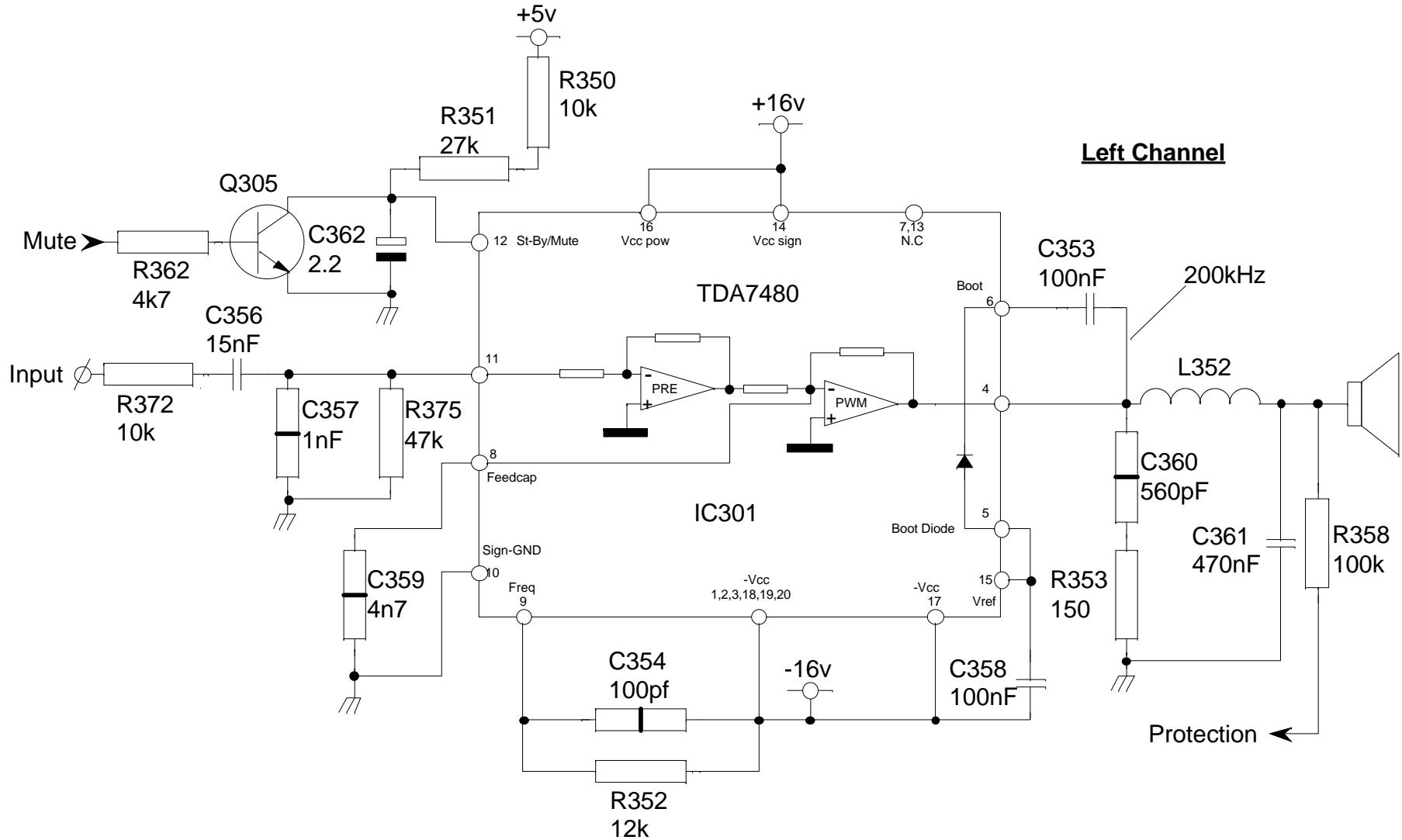

Line Output Stage

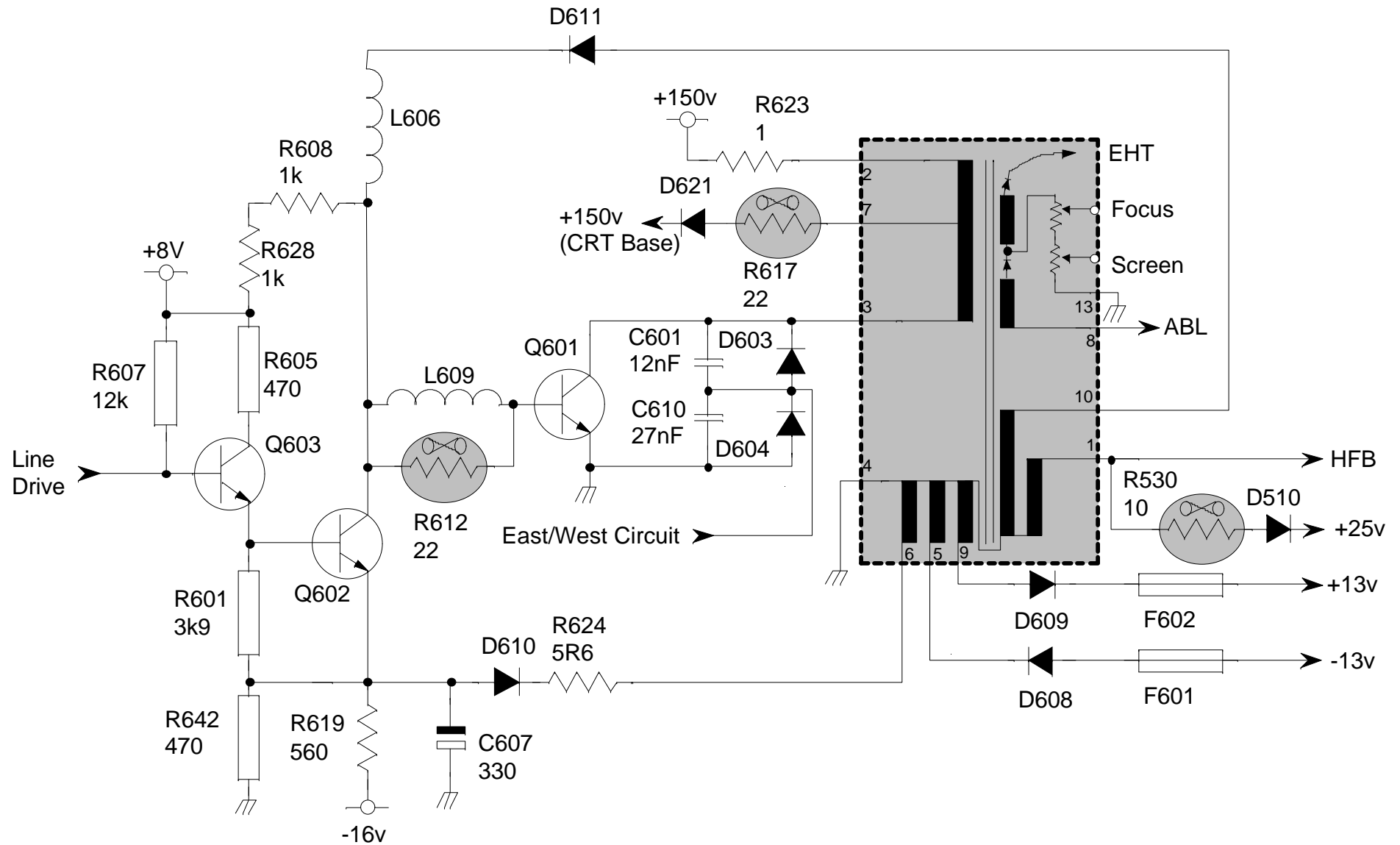

East West Correction

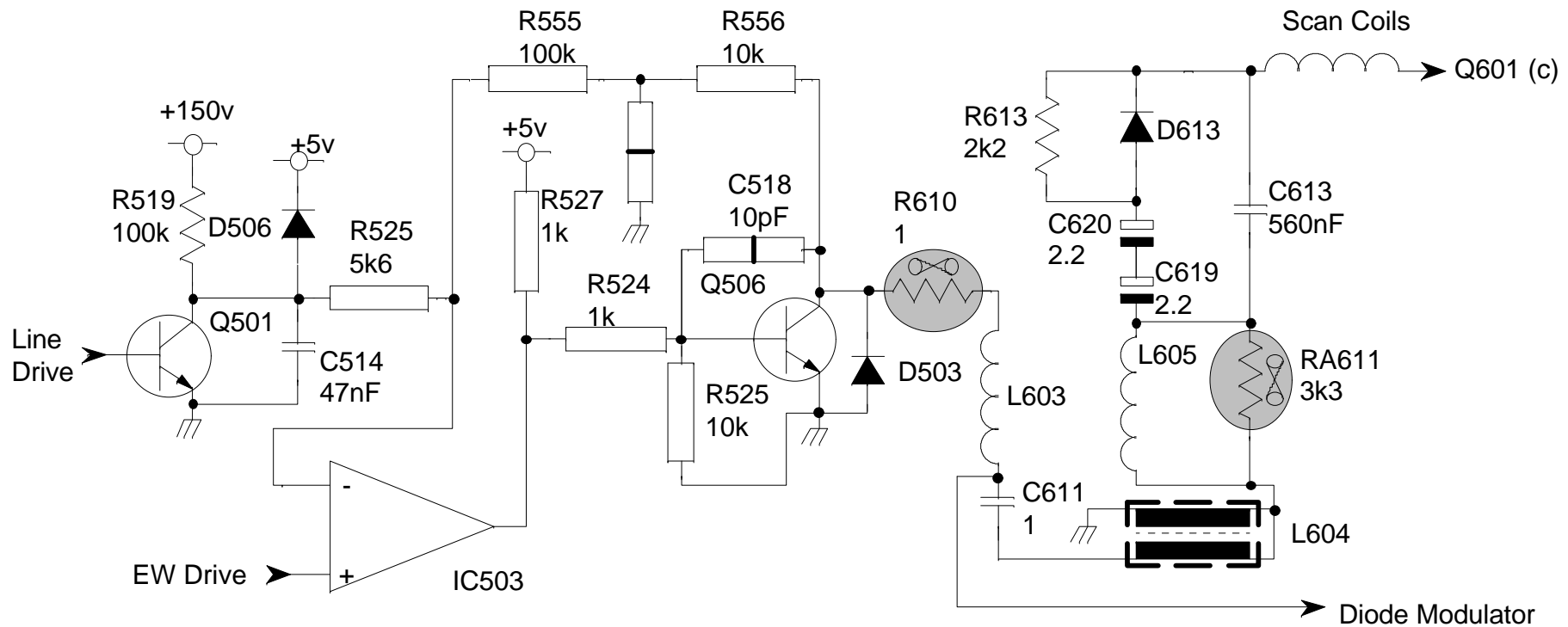

Focus Modulator

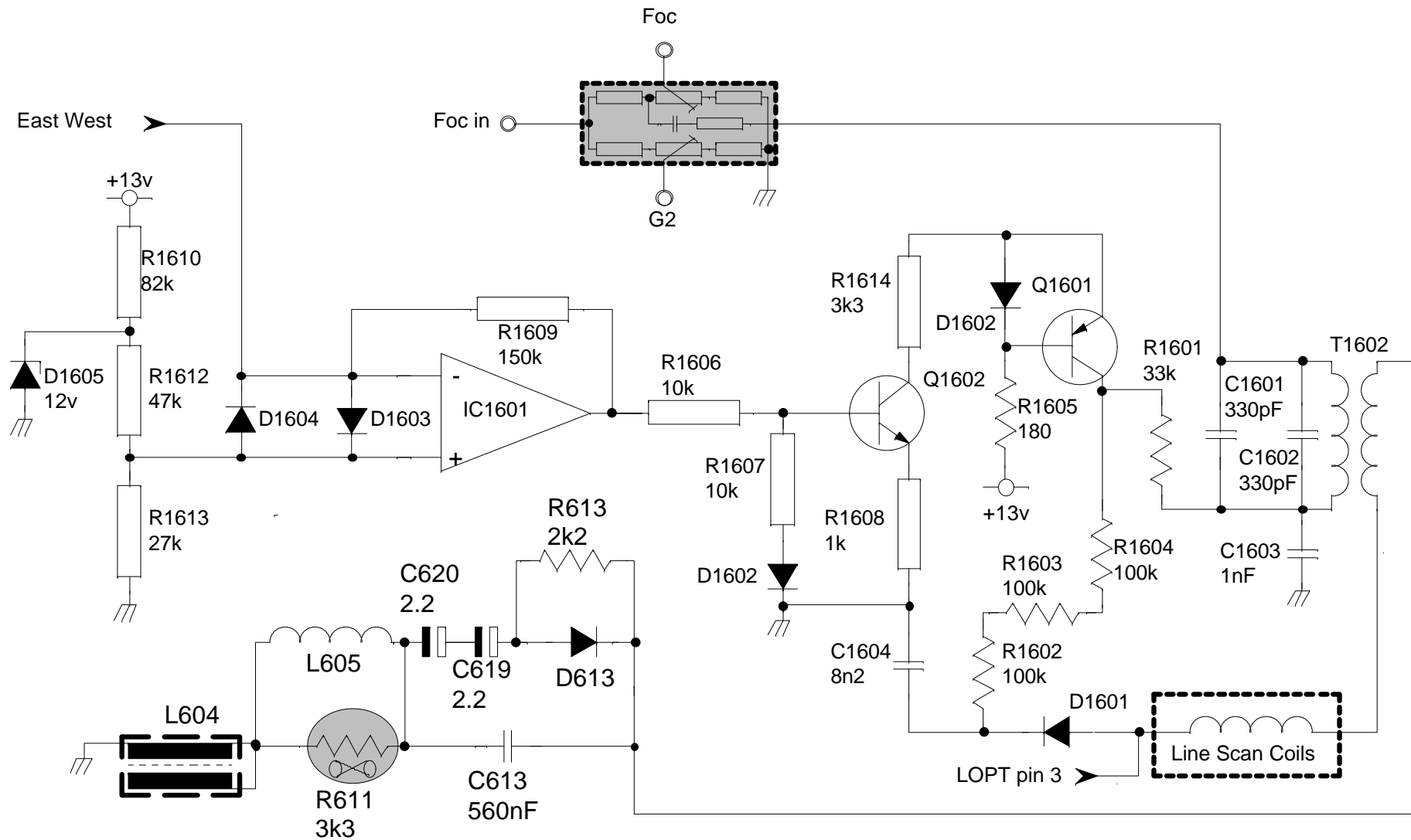

IC801 Block Diagram

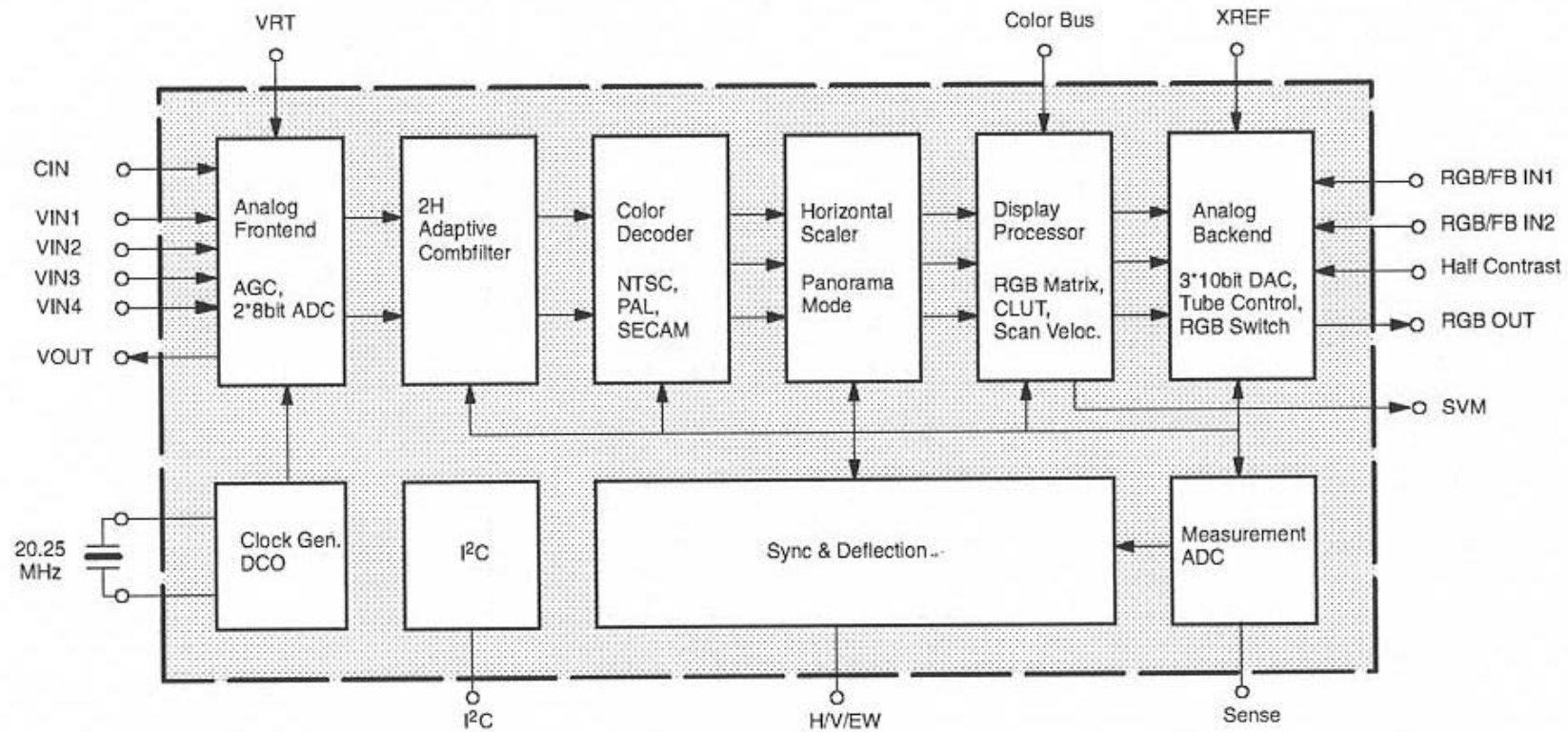

IC801 pin-outs

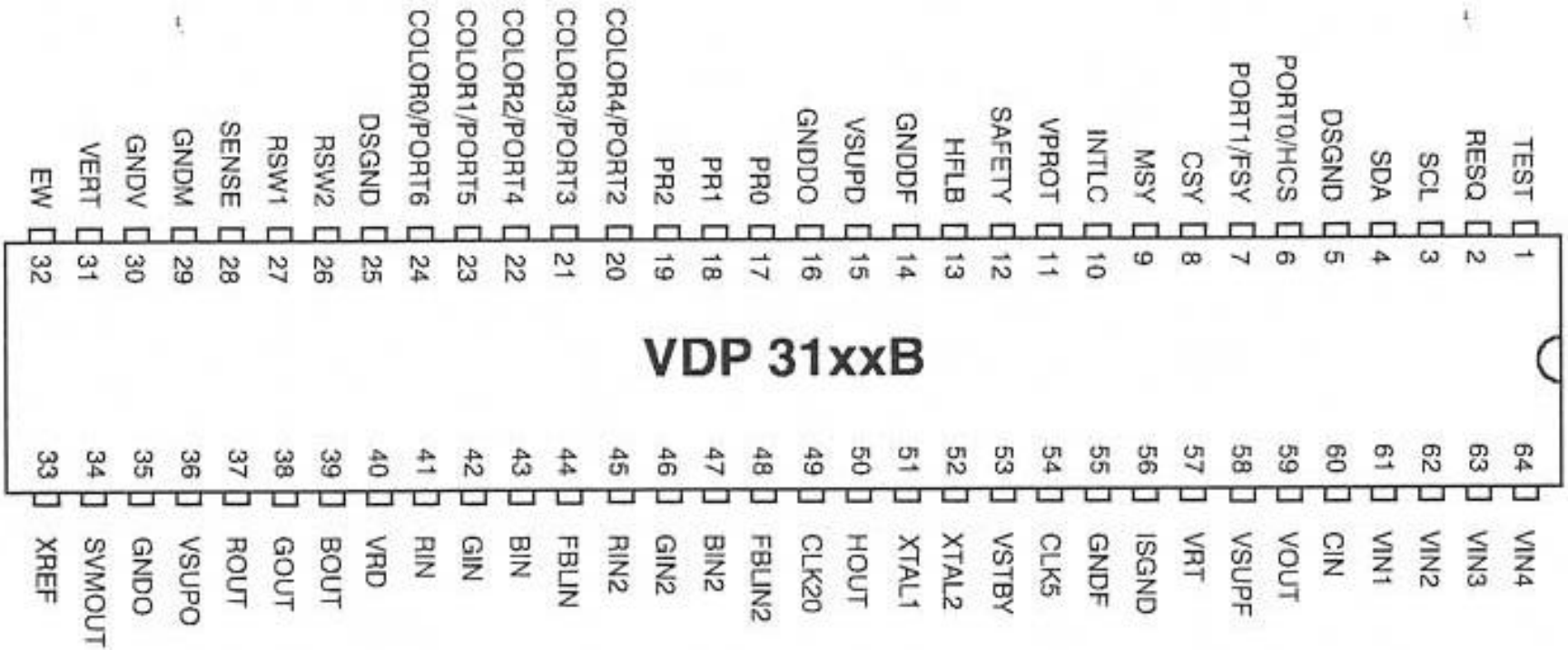

Scan Protection

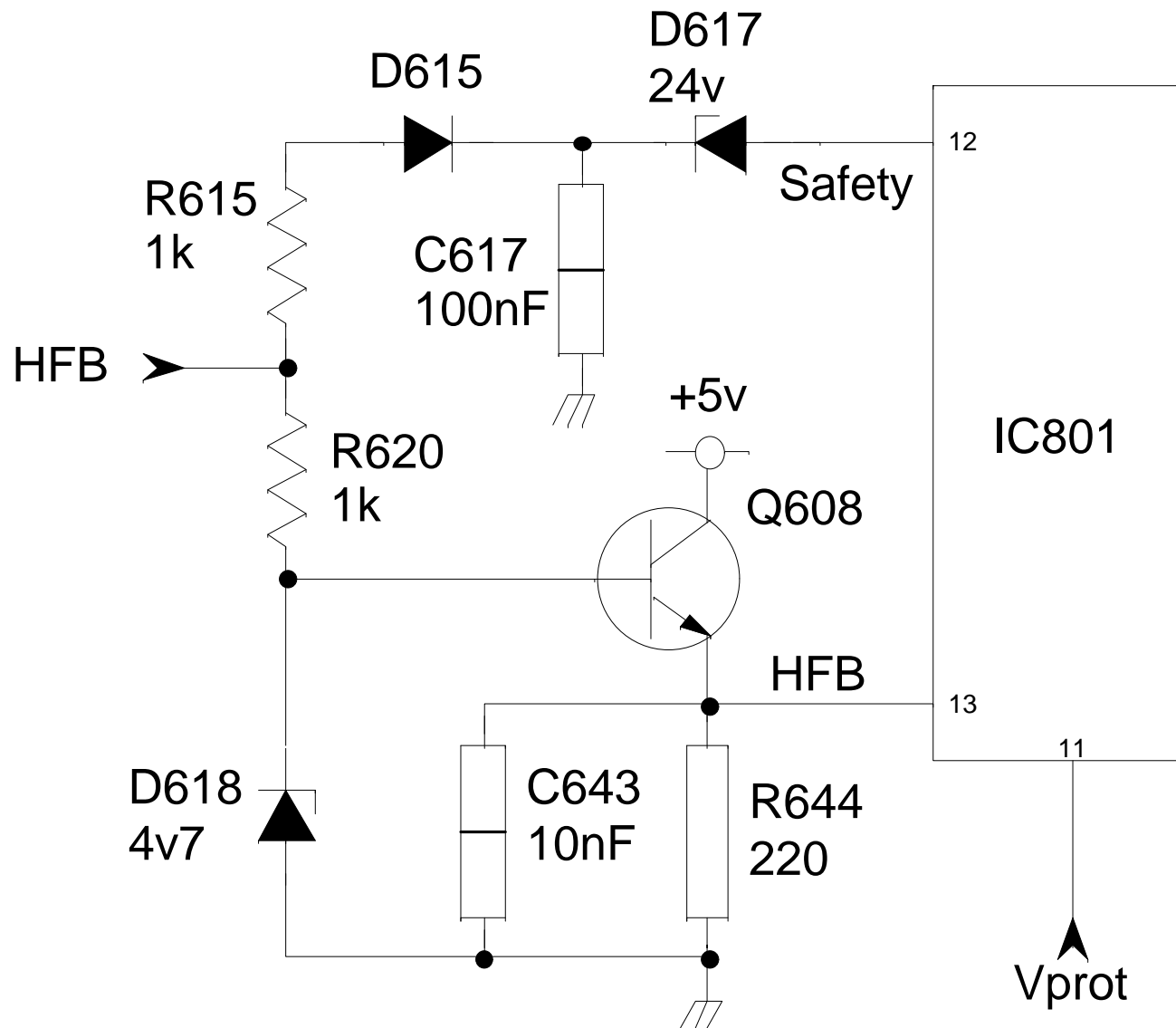

Scan Velocity Modulator

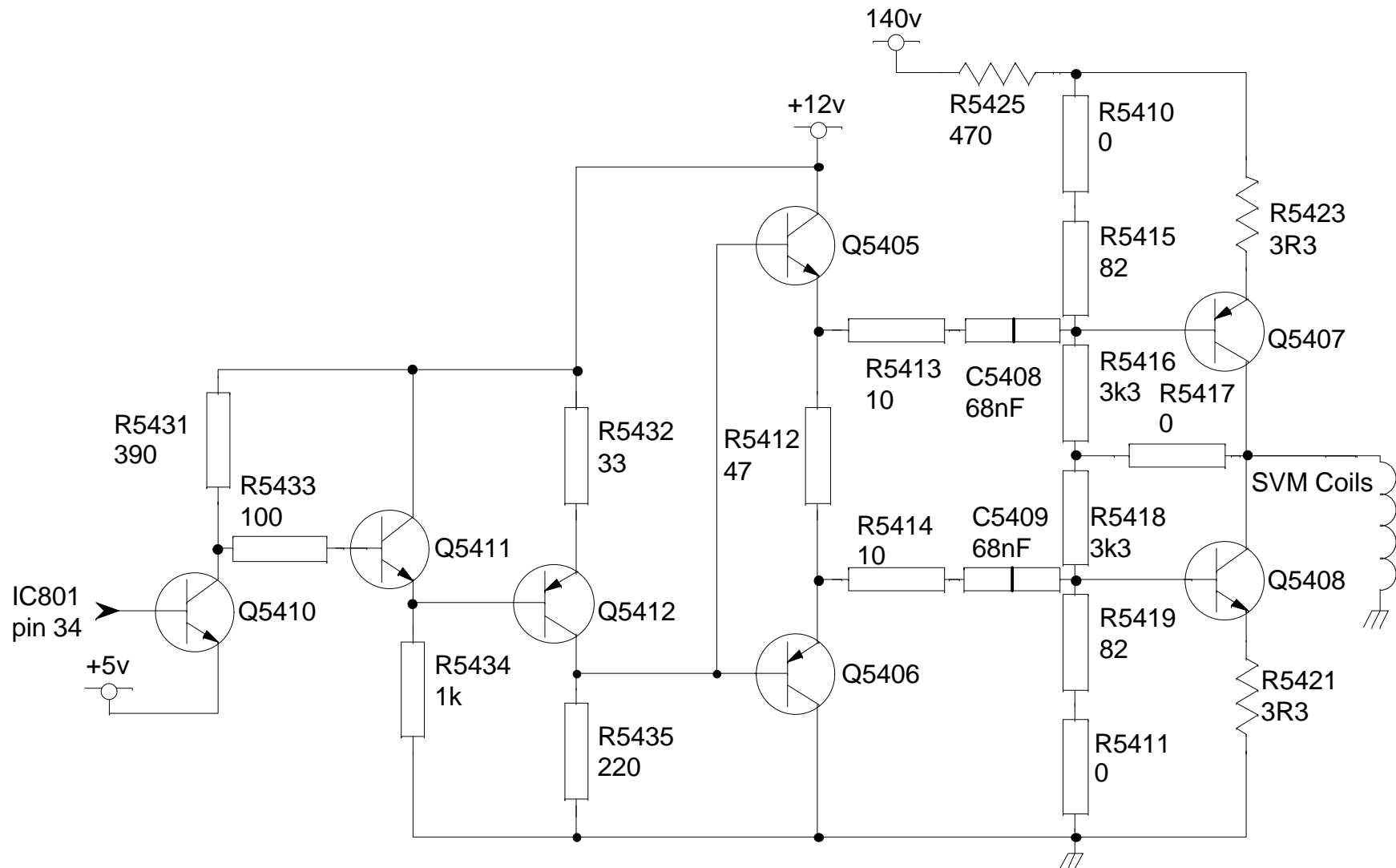

AGC Loop

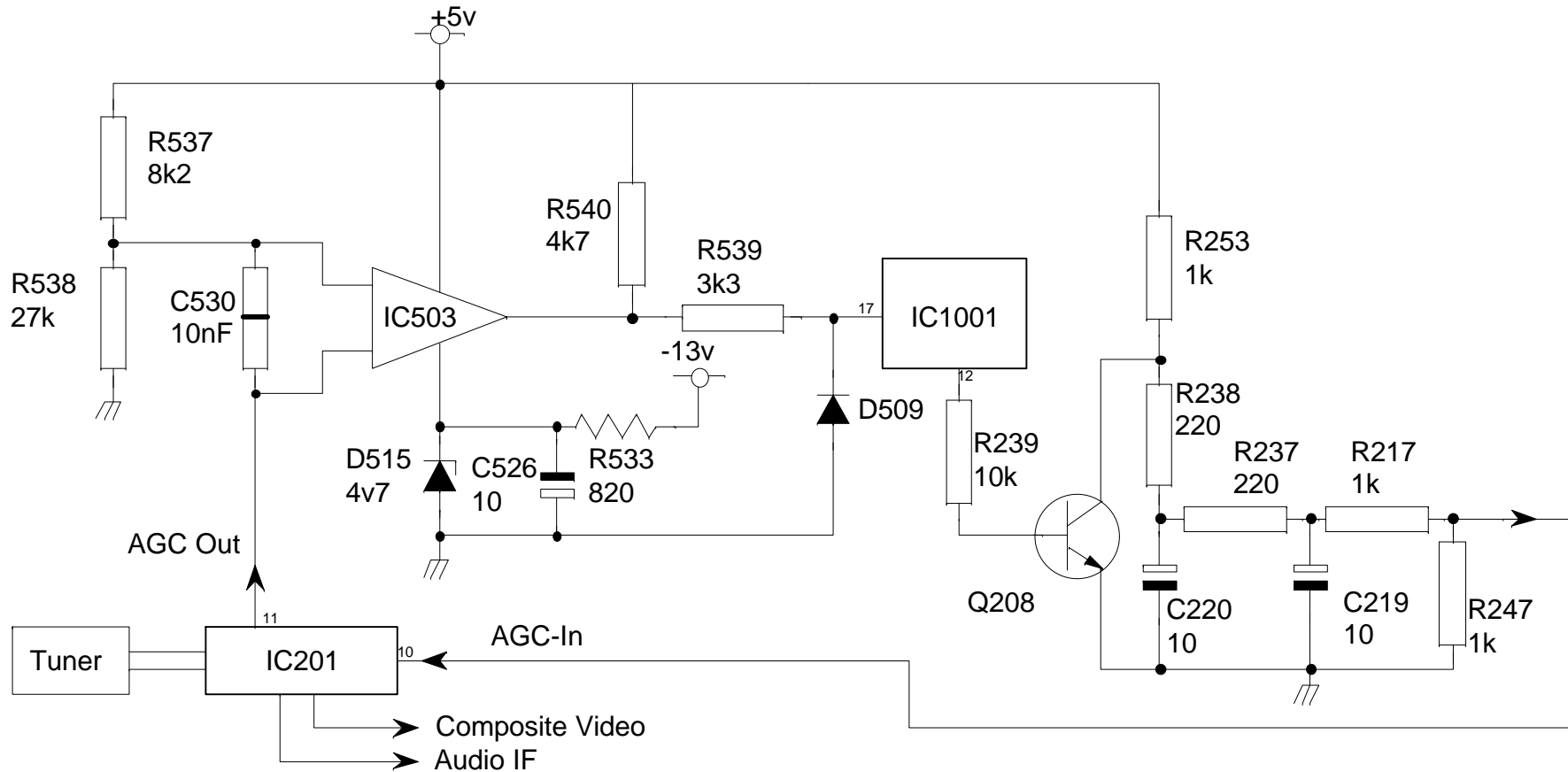

AFT Loop

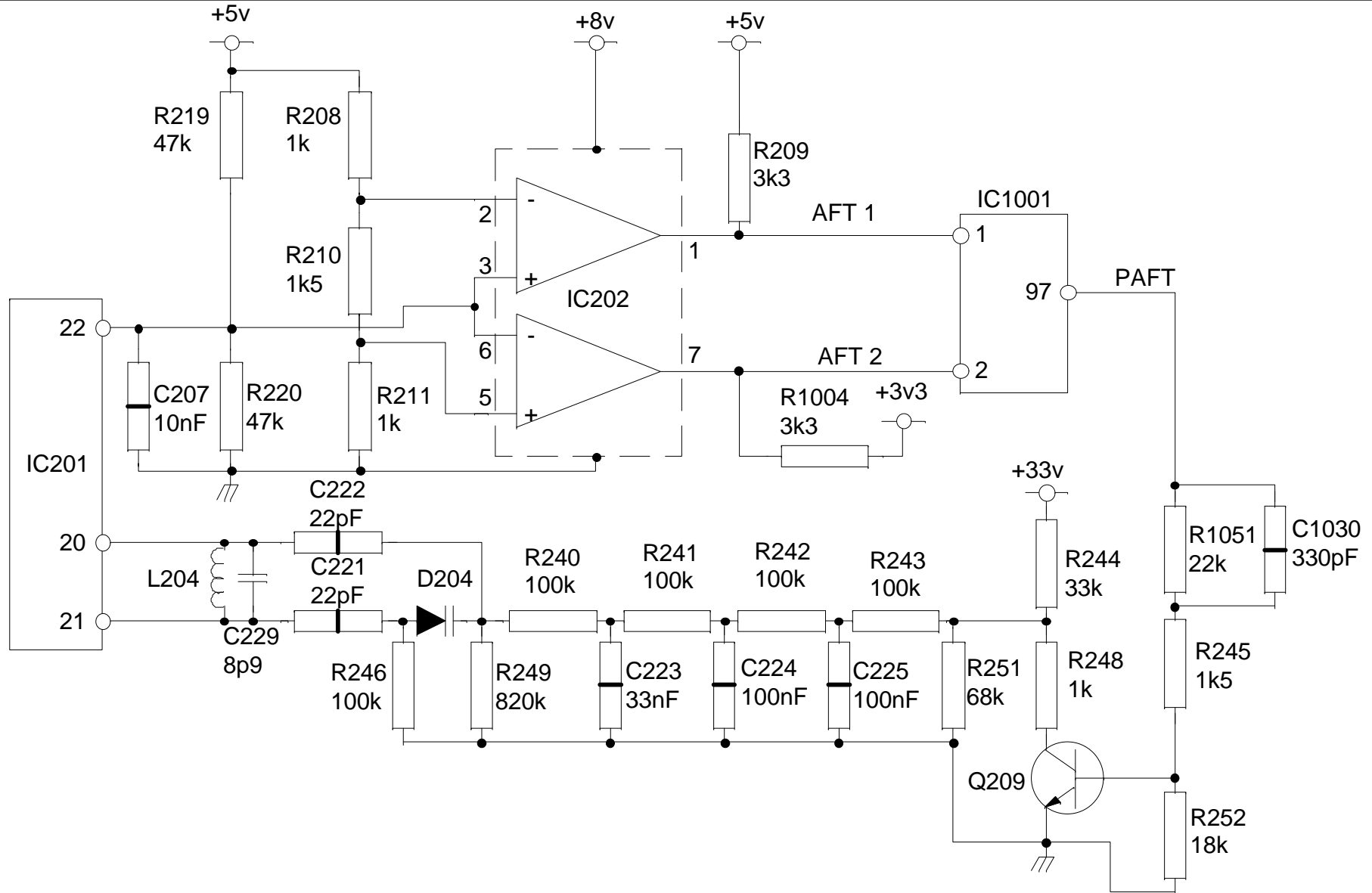

T701 - Pin 15

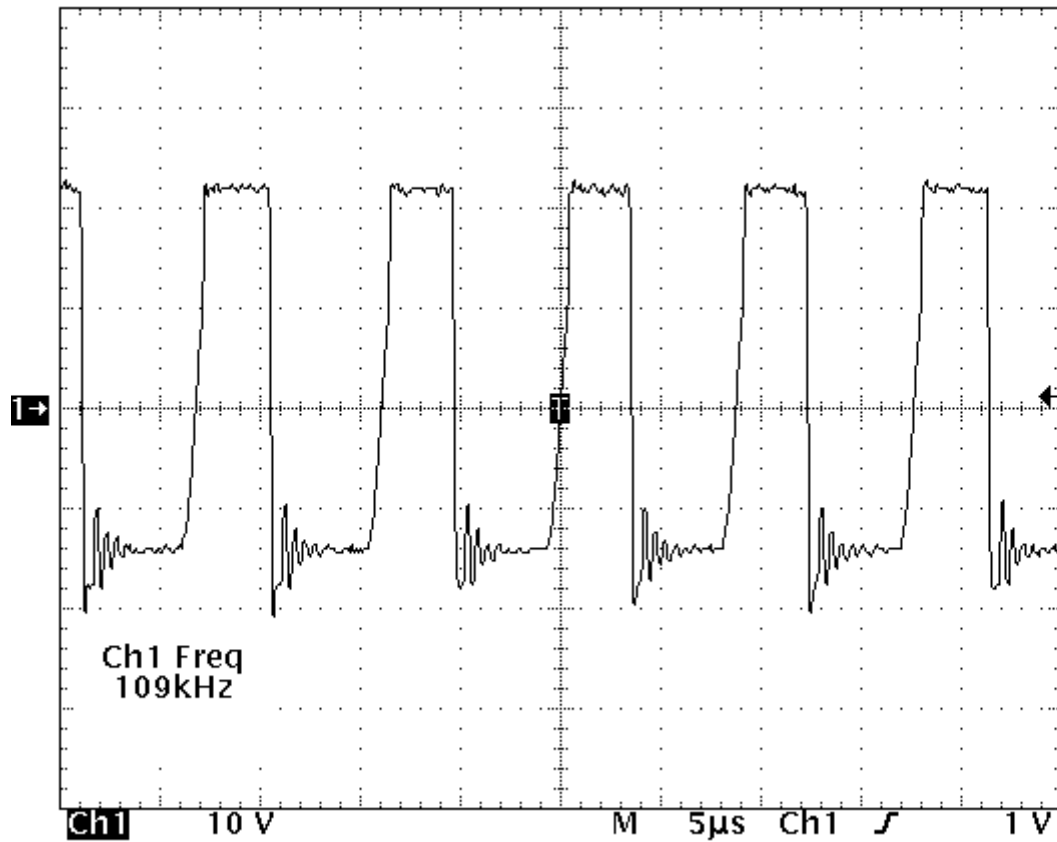

12:57:35

Vertical Protection

